

ALBIN ALP

Peristaltic pump

ALP PERISTALTIC RANGE

Reduce maintenance downtime ...

Albin pumps provide process confidence and offer cost savings through:

- Accurate and repeatable dosing and metering
- Long life and greater reliability
- Self-priming
- Continuous dry running
- Lowest cost of ownership
- Quick and easy maintenance

Self-priming and dry-running

It is not always possible to position a pump in the ideal location and often self-priming and dry-running performance is required. These conditions can cause wear in conventional pumps, resulting in loss of flow and premature failure. Albin Pump can self-prime up to 9.8 metres and run dry indefinitely.

Lowest cost of ownership with quick and easy maintenance

Leakage, clogging or blockage of conventional positive displacement pumps which incorporate seals, valves, lobes, rotors or vanes can be a regular occurrence and expensive to rectify. Albin pumps contain the fluid in a tube or hose, requiring only one component to be changed, which means that maintenance costs are considerably lower than other pump types. Increased plant productivity and lower repair costs means pump payback is over months rather than years.

Accurate and repeatable dosing and metering

Industry requires repeatable pump control for accurate dosing. Many traditional positive displacement pumps deliver varying flow rates, resulting in scrapped product and increased costs. Albin pumps are accurate up to $\pm 0.5\%$ across their total speed range, with the additional benefit of process control capabilities which allows easy installation.

Less waste means increased profits.

Long life and greater reliability

Pump failure cannot be tolerated. Albin pumps have no seals, valves, diaphragms, glands or immersed rotors to leak, clog or replace. Abrasive, corrosive and aggressive liquids are handled with ease because the fluid stays within the tube and never comes into contact with moving parts of the pump. The ALP range is designed and manufactured for industrial use, and advanced elastomer technology ensures accurate and repeatable performance that truly outperforms all other pumps.

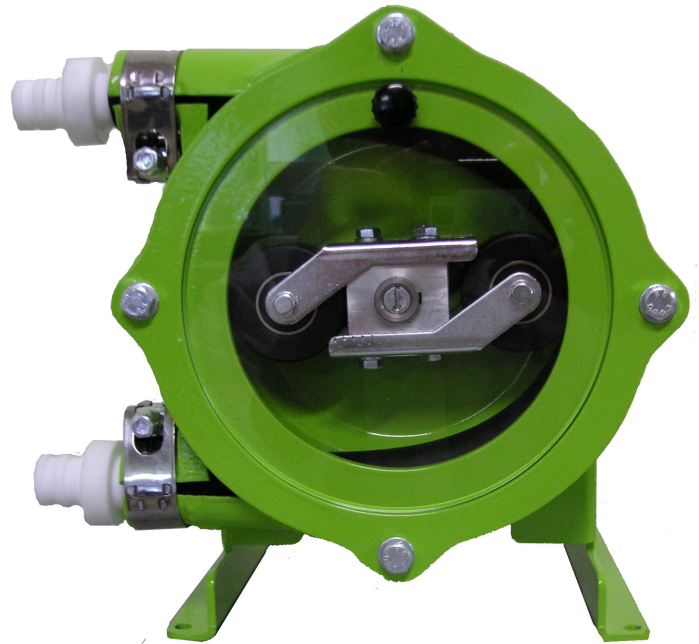

... Using a proven design ...

Two rollers on a rotor compress alternating with each other a thick-walled hose in a patented concentric guide and push on account of the rotation the content of the hose (the pumped liquid) from the suction to the discharge side. Through the subsequent opening of the hose a vacuum on the suction side is created by which a continuous aspiration results.

No other positive displacement pump offers this unique separation of pump and fluid.

Albin pumps clearly outperform other pumps which rely on seals, valves or vanes for their operation. These components are repeatedly the cause of pump failure and high maintenance.

In sizes ALP09-ALP17, the rotor is supported by oversized ball bearings located within the pump casing; in sizes ALP25 - ALP45 the rotor is supported by the heavy-duty bearings of the flanged drive unit.

Liquids are conveyed within the hose and do not get in contact with any metal part.

The Albin pump ALP range provides flow rates from microlitres per minute to 10 m³/h and pressures up to 4 bar. Fixed, variable, flameproof, and air operated drives, with comprehensive control options to enable pumps to be configured to your requirements.

... With expert advice to give the best system and installation

... To deliver the promised results.

All our customers have made major improvements in process performance, maintenance and product quality, resulting in cost savings previously thought unavailable.



OPERATING DATA

Capacity	10 m ³ /h
Viscosity	15000 cps (3)
Temperature of pumped liquid	100°C (1)
Differential pressure	4 bar (2)
Achievable suction	0.6 bar (3)

1- At a room temperature of 20°C. Furthermore, it depends on the pumped fluid, on the hose quality and on the motor construction.

2- It depends on the pump dimension and on the hose quality.

3- It depends on the pump dimension/execution, on the speed and on the pumped fluid

ALP TUBING

Albin Pump SAS have selected the most comprehensive range of tubing to suit all the specific need of the industry.

Material	Hose Identification	Operating Temperatures	Industry Approvals
Neoprene	Flat black color, rough surface, rubber smell	0 to 60°C	
Varprene	Off white, smooth surface	-35 to 135°C	USP Class VI
			FDA 21
			CFR 177.2600
			NSF listed (Standard 51)
Silicone	Rust color, smooth surface	0 to 140°C	USP Class VI
			FDA 21
			CFR 177.2600
Pharmed®	Cream color, Pharmed* name on hose	-30 to 135°C	USP Class VI
			FDA 21
			CFR 177.2600
			NSF listed (Standard 51)
Hypalon	Black color, yellow stripe, double braided	0 to 90°C	
EPDM Rubber	Black color, white stripe, double braided	0 to 90°C	
Natural Rubber	Black color, no stripes,	0 to 80°C	
Nilrile Rubber	Black color	0 to 80°C	

® Pharmed Reg. Saint-Gobain Performance Plastics

TUBE DIMENSIONS

SIZE	ID	OD	Length
	mm		
ALP 09	9	16	330
ALP 13	13	22	390
ALP 17	17	31	590
ALP 25	25	43	860
ALP 30	30	55	1150
ALP 45	45	75	1455



ALBIN PUMP PERISTALTIC IN YOUR INDUSTRY

Albin pumps are exceptionally low shear, ensuring product quality, accurate and predictable performance with subsequent cost savings.

Pharmaceutical industry

Challenge: it demand sterility and a high degree of precision to ensure the integrity and quality of the end product. Fluid isolation and precise metering are vital, and not meeting these demands can be enormously costly.

Fluids Pumped: chemical dosing, liquid proteine, vaccines, serum, plasma, syrups.

Water treatment:

Challenge: reduce the down time due to maintenance of costly dosing pumps and elimination of expensive ancillary equipment.

Fluids Pumped: sodium hypochlorite, ferric chloride, sodium bisulfite, fluoride, polymers, aqueous ammonia, potassium permanganate, caustic soda.

Pasta industry

Challenge: Inspectors are concerned about contamination if the hose breaks. Our competition uses a food grade oil for hose lubrication, but within 1-2 days the hose begins to wear (turns black), requiring the customer to change hoses every 2 days.

Fluids Pumped: egg white & yolk, edible fat, semolina, natural flavoring.

Cheese manufacturer

Challenge: Requires a low shear pump so fibers in cheese aren't separated.

Fluids Pumped: Cream, milk and yogurt.

Bread Dough & Fruit Cake Manufacturer's

Challenge: Require semi-accurate metering of viscous products containing solids.

Fluids Pumped: Water & salt mixtures, natural flavorings, fats, fruit cake dough/mixture (i.e. fruit cake has nuts and fruit pieces that need to stay whole).

Shampoo manufacturer

Challenge: Eliminate potential for foaming fluid on bottle filling lines. Harsh pumping action of air operated diaphragm pumps can cause the fluid to foam.

Fluid: Shampoos

STANDARD MOTORIZATION

Gear motors or variable speed motors, both TEFC and flame-proof, electronic gear motor, inverters. Upon request, pneumatic drive units are available.

F = Geared motor only

VM = Mechanical variator

Designation	L/h	R.p.m.	Motor	Bar	Kw	Hp	Kg
ALP 09-F	23,3	23,3	230/400 V 3 phases 50 Hz 4 poles	2	0,12	0,16	7
	35	35		2	0,12	0,16	7
	46,6	46,6		2	0,12	0,16	7
	70	70		2	0,12	0,16	7
ALP 09-VM	15 to 90	15 to 90		1,5	0,18	0,25	12
	15 to 140	15 to 140		1,5	0,18	0,25	12
ALP 13-F	87	35		2	0,12	0,16	9
	116	46,6		2	0,12	0,16	9
	174	70		2	0,12	0,16	9
	348	140		2	0,12	0,16	9
ALP 13-VM	37 to 225	15 to 90		1,5	0,18	0,25	13,5
	37 to 350	15 to 140		1,5	0,18	0,25	13,5
ALP 17-F	260	40		1,5 to 4	0,18	0,25	15,5
	455	70		1,2 to 3	0,18	0,25	15,5
	910	140		1,0 to 3	0,18	0,25	15,5
ALP 17-VM	87 to 787	3,5 to 121		1,2 to 3	0,25	0,33	23
ALP 25-F	620	32		2,5	0,37	0,5	35
	800	41		2,5	0,37	0,5	35
	1350	69		2	0,55	1,75	38
	1920	98		2	0,55	0,75	38
	2780	143	1,5	0,55	0,75	38	
ALP 25-VM	170 to 840	8,7 to 43	2	0,55	0,75	51	
	310 to 1540	16 to 79	2	0,55	0,75	51	
	410 to 2050	21 to 105	2	0,55	0,75	51	
ALP 30-F	1530	37	4	1,1	1,5	75	
	2450	59	3	1,5	2	78	
	3450	83	3	1,5	2	78	
	4440	107	2	1,5	2	78	
ALP 30-VM	415 to 2075	10 to 50	2,5	1,5	2	96	
	1040 to 5230	25 to 126	2,5	1,5	2	96	
ALP 45-F	4270	37	4	1,5	2	118	
	6230	54	3	1,5	2	118	
	7970	69	3	2,2	3	125	
	10160	88	2	2,2	3	125	
ALP 45-VM	2190 to 10740	19 to 93	3	3	4	152	

CONSTRUCTION

Description	Material design
Pump casing	Aluminium alloy
Rotor	Aluminium alloy
Pressure rollers	Plastic or light alloy (1)
Pump tubing	Various elastomers
Extruded or reinforced by polyamide fabrics (2)	

(1) According to pump size

(2) According to pumped liquid and to operating conditions

ALP 09 to ALP 17

SIZE	G	H	I	L	W	A	D	F	R	S	T	U	V	Y	Z	B	C	E	M	N	O
ALP 09F	104	41	15	20	50	194	-	93	312	45,5	19	12	132	4,5	187,5	150	138	6	170	156	7
ALP 09VM	104	41	15	20	50	194	-	93	312	45,5	19	12	132	4,5	187,5	150	138	6	170	156	7
ALP 13F	132	49	19	20	51	215	-	115	334	46	25	12	166	9,5	196	170	158	6	170	156	7
ALP 13VM	132	49	19	20	51	215	-	115	334	46	25	12	166	9,5	196	170	158	6	170	156	7
ALP 17F	190	65	25	35	77,5	310	5	160	432	54,5	35	18	236	13,5	235,5	235	220	7,5	200	180	10
ALP 17VM	190	65	25	35	77,5	310	5	160	432	54,5	35	18	236	13,5	235,5	235	220	7,5	200	180	10

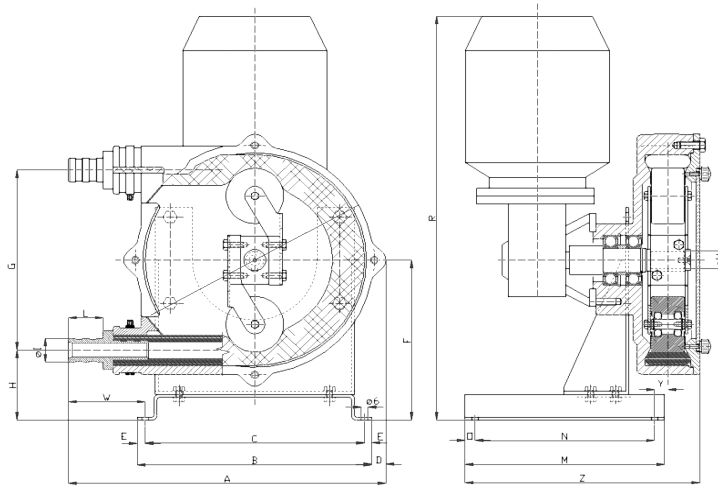

ALP 25 to ALP 45

SIZE	a1	A	I	L	X	D	F	G	H	P	R	S	T	U	V	Y	Z	B	C	E	J	M	N	O
ALP 25F	486	443	35	45	275	33	218	256	90	42	386	35	50	25	94	20	130	270	240	15	11	440	400	20
ALP 25VM	665	443	35	45	275	33	218	256	90	42	386	35	50	25	94	20	130	270	240	15	11	440	400	20
ALP 30F	530	571	45	55	345	36	330	364	148	55,5	556	20	60	30	113	22	180	380	330	25	14	600	550	25
ALP 45F	659	727	60	70	395	97	385	456	157	81	672	50	80	40	161	35	230	470	420	25	14	700	650	25
ALP 30VM	710	571	45	55	345	36	330	364	148	55,5	556	20	60	30	113	22	180	380	330	25	14	600	550	25
ALP 45VM	861	727	60	70	395	97	385	456	157	81	672	50	80	40	161	35	230	470	420	25	14	700	650	25

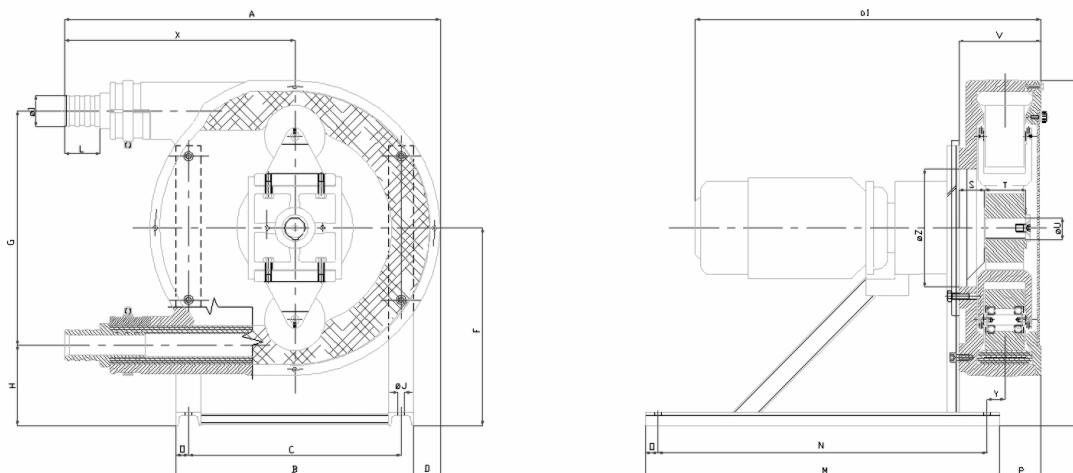



Albin Pump SAS
Z.A de Fontgrave
26740 Montboucher
France
Tel +33 (0) 4 75 90 92 92
Fax +33 (0) 4 75 90 92 40
info@albinpump.fr
www.albinpump.com